

Scala 1:1

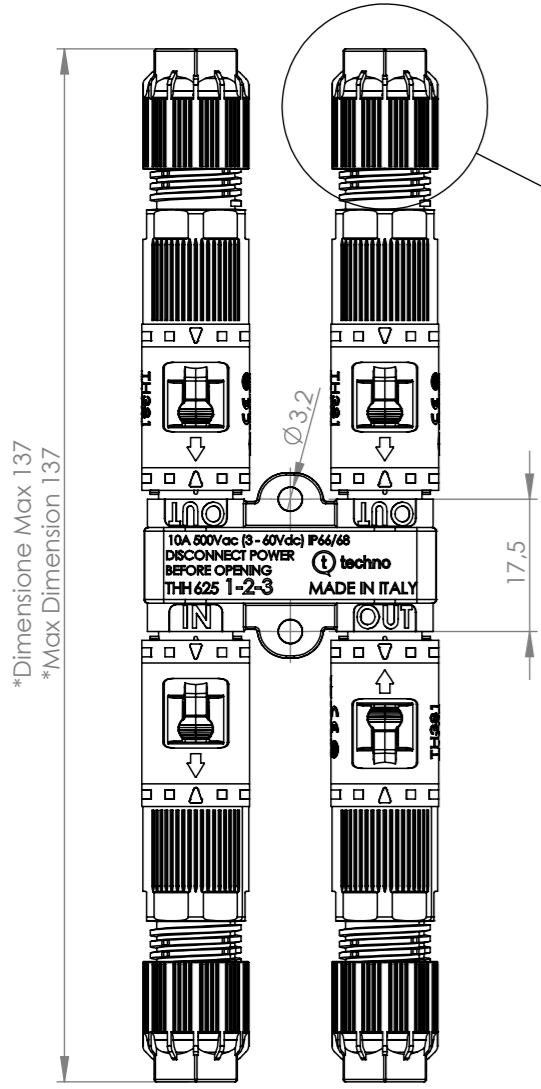

*Dimensione Max 137
*Max Dimension 137

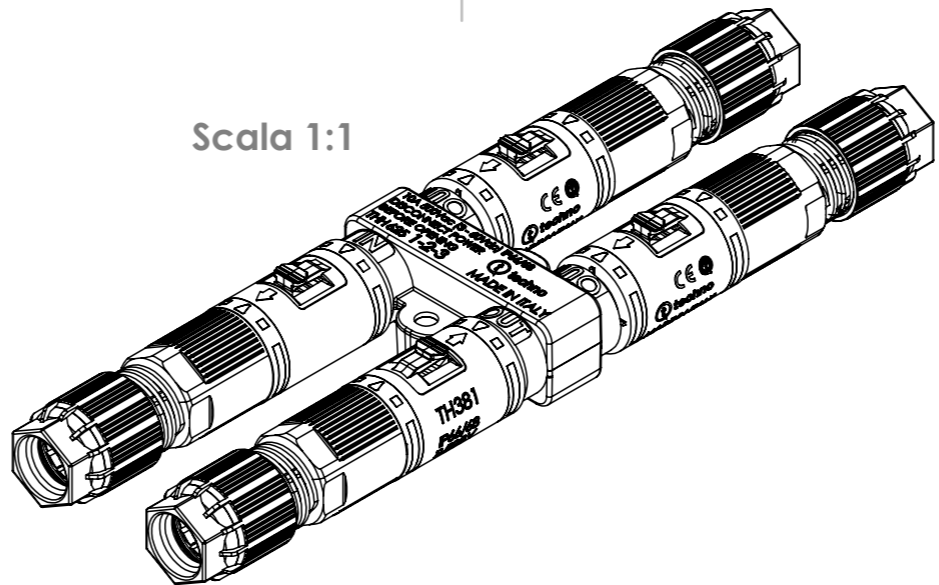
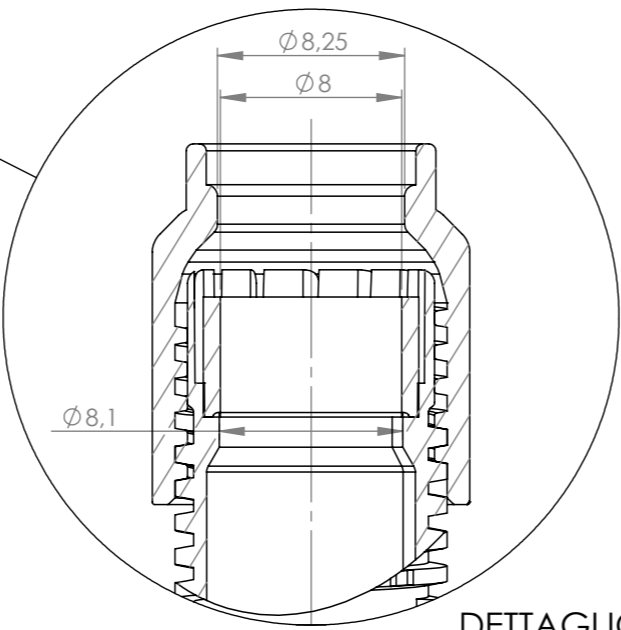

DETTAGLIO B
SCALA 3:1

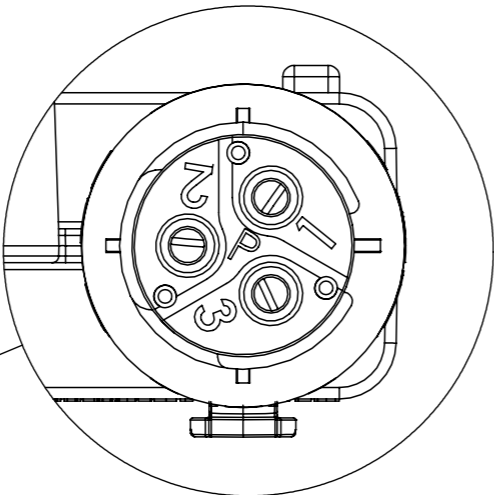

DETTAGLIO A
SCALA 3:1

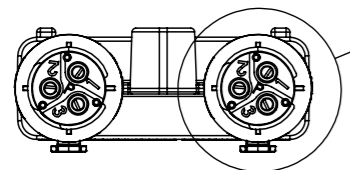

Tolleranze generali Particolari stampati in materiale termoplastico: rif ISO 2768MK - Particolari lavorati alle macchine utensili: rif. UNI EN 22768
Particolari tranciati in metallo: rif. UNI EN 22768 - grado IT10 per dim. lineari - grado IT11 quote di piega - angoli di piega ± 1

ACCESSORI / ACCESSORIES



6000473GT

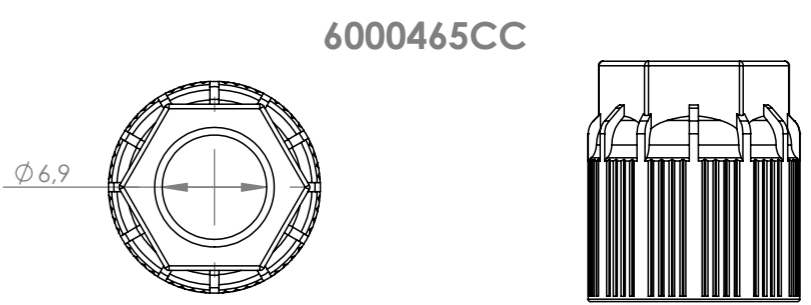

6000465CC

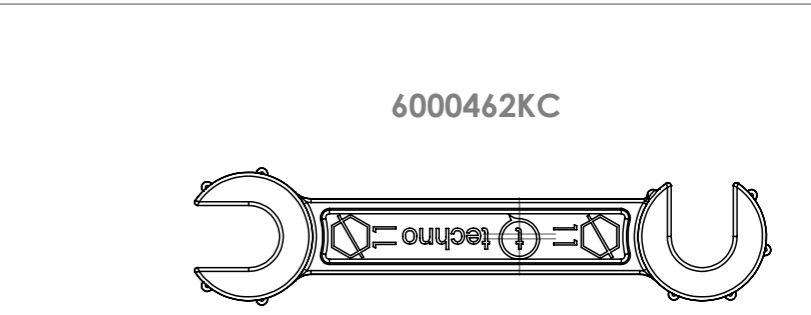

6000462KC

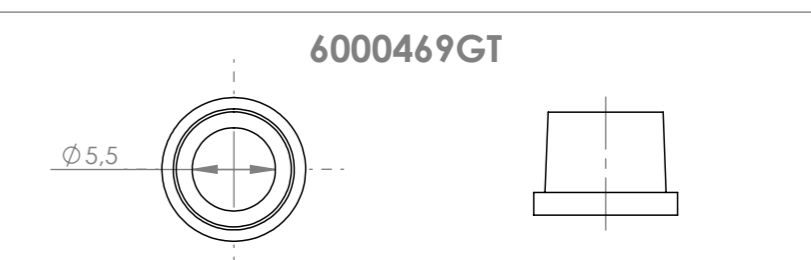

6000469GT

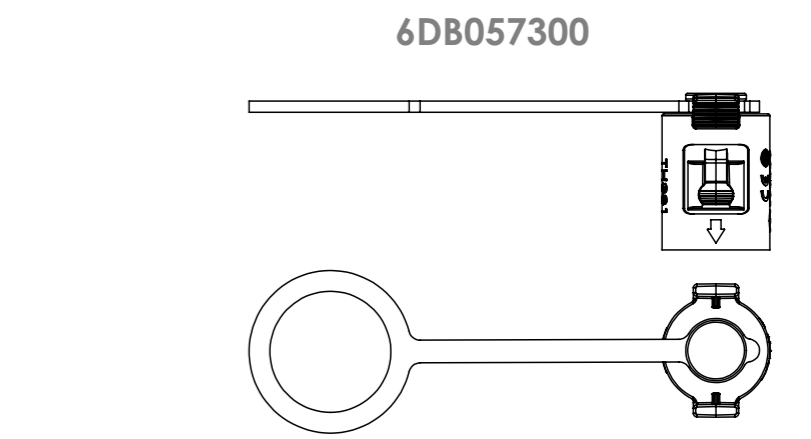

6DB057300

*=Quota variabile per tipologia di cavo
Variable dimension by type of cable

Materiale-Material:			Titolo-Title:		
Trattamento-Treatment:			Kit Distributor Paral 4Ways 3P IP68		
N° documento cliente Customer ref		Peso [gr]: Weight [gr]:	59.92	Progetto-Project:	
Disegnato - Drawn by:	G.Flores	Data: Date:	2024-12-05	TH625	
Disegnato - Drawn by:	G.Flores	Scala-Scale:	1:1	N° Disegno - Drawing N° THH.625.A3A.R	
Controllato-Checked by:	M.Strada	Data: Date:	2024-12-05	Formato - Format	A3
					Nome file - Filename THH.625.A3A.R
			Rev.	Foglio N° Sheet N°	N° Fogli N° of sheets
			00	1	1