

Tolleranze generali

Particolari stampati in materiale termoplastico: rif ISO 2768MK - Particolari lavorati alle macchine utensili: rif. UNI EN 22768
 Particolari tranciati in metallo: rif. UNI EN 22768 - grado IT10 per dim. lineari - grado IT11 quote di piega - angoli di piega ± 1

ACCESSORI/ACCESSORIES

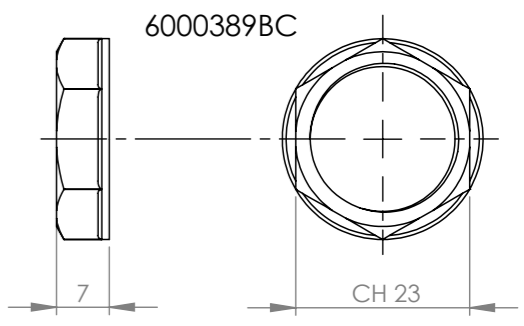

*= Dimensione con pannello max 3mm
 Max dimension with panel 3mm

*Dimensione max 21
 *Max dimension 21

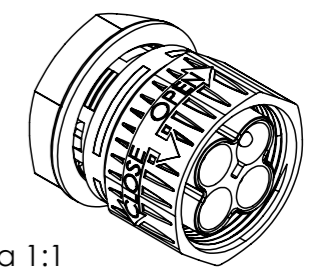
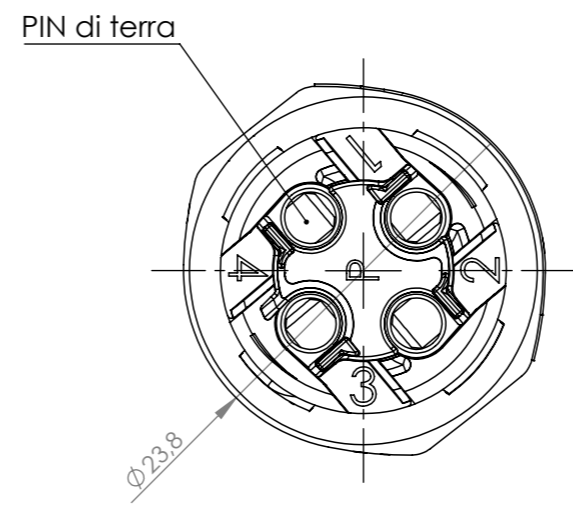
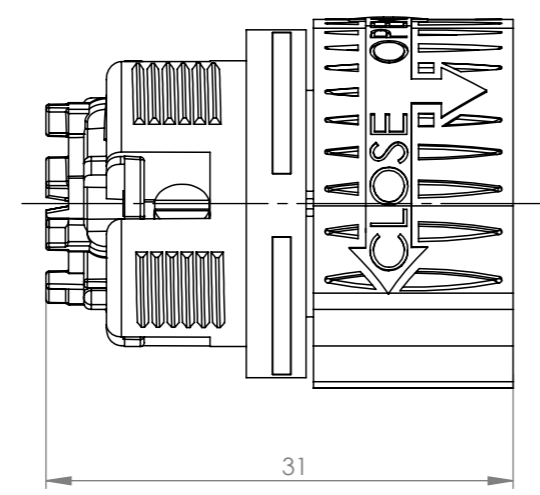
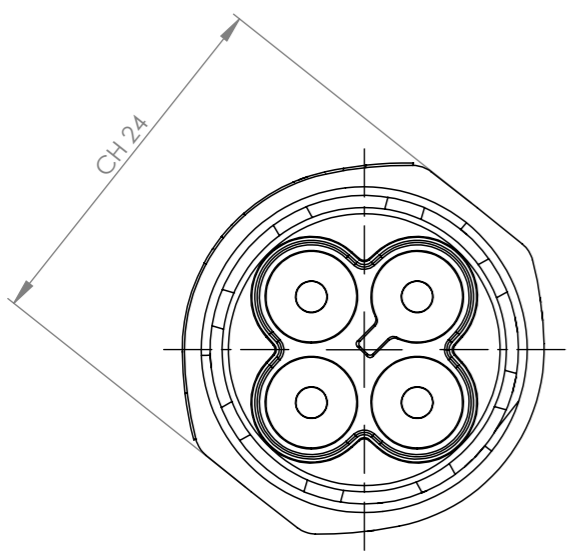
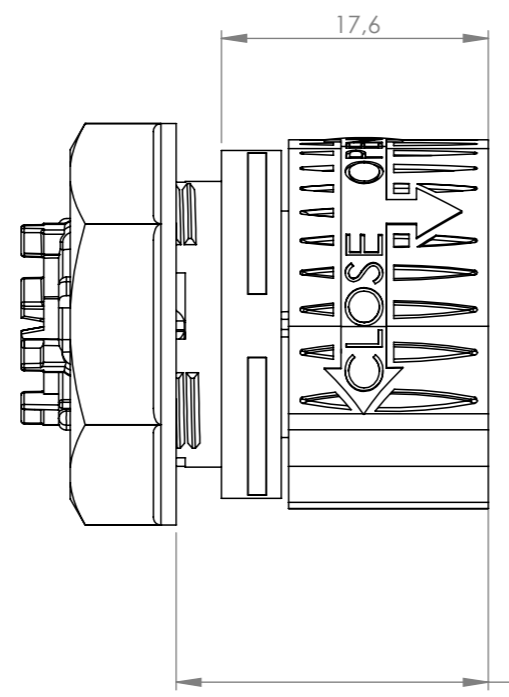

Questo disegno è proprietà esclusiva di Techno e non può essere copiato, ristampato, o comunque utilizzato senza autorizzazione scritta della Techno s.p.a. integralmente o parzialmente, without Techno written authorization. This drawing and all informations contained here can not be used or reproduced.	Materiale-Material:		Titolo-Title:		
	Trattamento-Treatment:		Plug 4P a pannello UP		
	N° documento cliente Customer ref	Peso [gr]: Weight [gr]:	15.79	Progetto-Project:	
	Disegnato - Drawn by: E.Negroni	Data: 2023-02-15	Scala-Scale: 2:1	TH387	
Controllato-Checked by: M.Strada	Data: 2023-03-02	Formato - Format A3	N° Disegno - Drawing N° THB.387.S4AU		
				Nome file - Filename THB.387.S4AU	
				Rev. 00	Foglio N° Sheet N° 1