

Tolleranze generali

Particolari stampati in materiale termoplastico: rif ISO 2768MK - Particolari lavorati alle macchine utensili: rif. UNI EN 22768  
 Particolari tranciati in metallo: rif. UNI EN 22768 - grado IT10 per dim. lineari - grado IT11 quote di piega - angoli di piega ± 1

ACCESSORI/ACCESSORIES

6000389BC

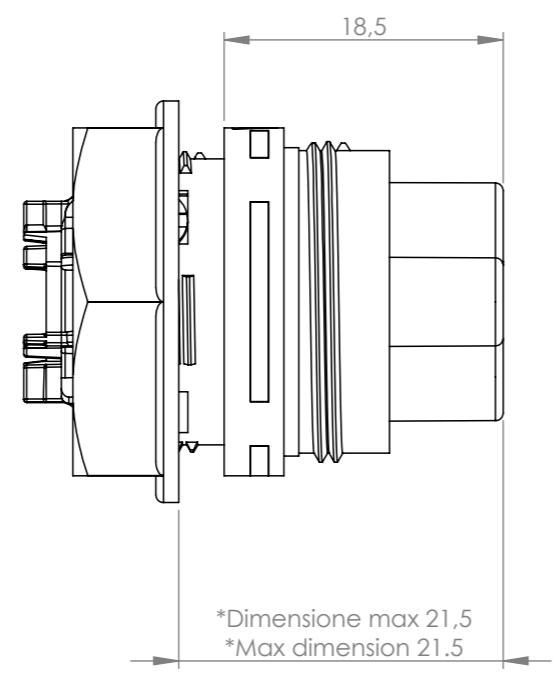
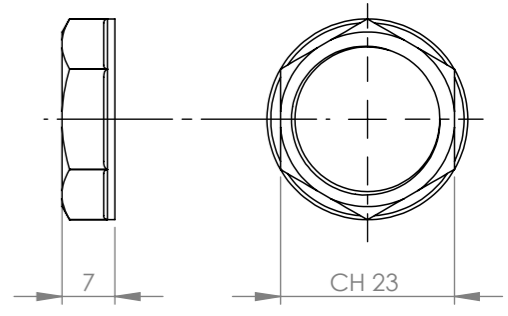

\*= Dimensione con pannello max 3mm  
 Max dimension with panel 3mm

\*Dimensione max 21,5  
 \*Max dimension 21.5

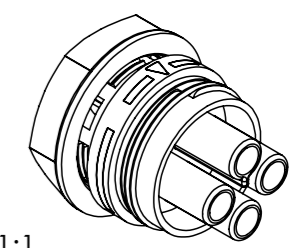
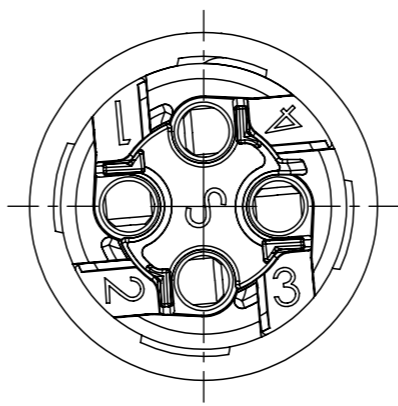
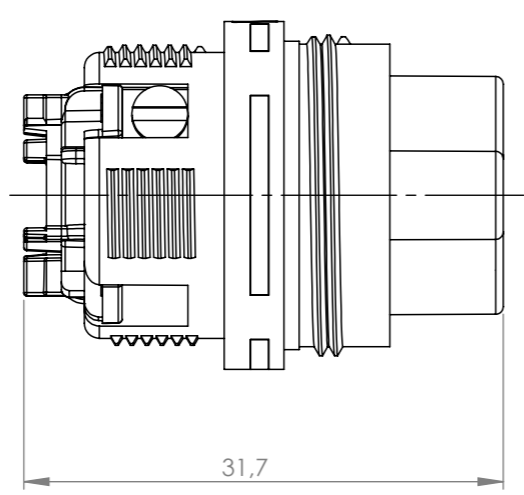
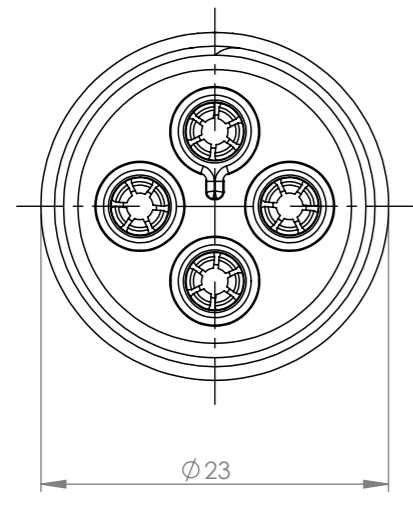

Scala 1:1

Questo disegno è proprietà esclusiva di Techno e non può essere riprodotto, modificato, copiato o utilizzato in alcun modo senza la scritta della Techno s.p.a. o senza la scritta di Techno s.p.a. in bianco o in grigio. This drawing and all informations contained here can not be used or reproduced, integrity or partially, without Techno written authorization.	Materiale-Material:			Titolo-Title:				
	Trattamento-Treatment:			Socket 4P a pannello UP				
	N° documento cliente Customer ref		Peso [gr]: Weight [gr]:		14.65			
	Disegnato - Drawn by: E.Negroni		Data: 2023-02-15		Scala-Scale: 2:1			
	Controllato-Checked by: M.Strada		Data: 2023-03-02		Formato - Format A3			
				N° Disegno - Drawing N°		Rev. 00	Foglio N° Sheet N°	N° Fogli N° of sheets
				THB.387.T4AU				
				Nome file - Filename		THB.387.T4AU		